



S-Series 500 Ice Cube Machine

Model

- | | | |
|-----------------------------------|-----------------------------------|-----------------------------------|
| <input type="checkbox"/> SD-0502A | <input type="checkbox"/> SY-0504A | <input type="checkbox"/> SD-0592N |
| <input type="checkbox"/> SD-0503W | <input type="checkbox"/> SY-0505W | <input type="checkbox"/> SY-0594N |



SY-0504A
Ice Machine on B-570 Bin

Standard Features

- Up to 560 lbs. (254 kgs.) daily ice production
- CEE Tier 3 energy and water efficiency rating
- Only 30" (76.20 cm) wide
- Removable water distribution tube with no tools
- Food zone designed with soft, round, cove corners
- Patented cleaning and sanitizing technology.
- Select components made with AlphaSan® antimicrobial.
- Hinged front door for easy access

Warranty

- 5-year parts and 5-year labor coverage on ice machine evaporator.
- 5-year parts and 3-year labor coverage on ice machine compressor
- 3-year parts-and-labor coverage on all other ice machine, dispenser, and storage bin components

Specifications

BTU Per Hour:

6,100 (average) 6,900 (peak)

Compressor:

Nominal rating: 3/4 HP

Cupra-Nickel Condenser:

(Water-cooled models)

Adds protection from corrosive water elements

Operating Limits:

- Ambient Temperature Range: Air and water-cooled: 35° to 110°F (1.6° to 43.3°C)
Remote: -20° to 120°F (-29° to 49°C)
- Water Temperature Range: 35° to 90°F (1.6° to 32.2°C)
- Water Pressure Ice Maker
Water In:
Min. 20 psi (137.9 kPA)
Max. 80 psi (551.1 kPA)
- Condenser Inlet Water In: (Water cooled only)
Min. 20 psi (137.9 kPA)
Max. 150 psi (1,034.2 kPA)

Ice Machine Electric

115/60/1 standard. (208-230/60/1 and 230/50/1 also available.)

Minimum circuit ampacity:

Air-cooled: 20 amps
Water-cooled: 13.5 amps
Remote: 20 amps

Maximum fuse size:

Air-cooled and Water-Cooled: 20 amps
Remote: 20 amps
HACR-type circuit breakers can be used in place of fuses.





S-Series 500 Ice Cube Machine

S-500 on B-570 Storage Bin

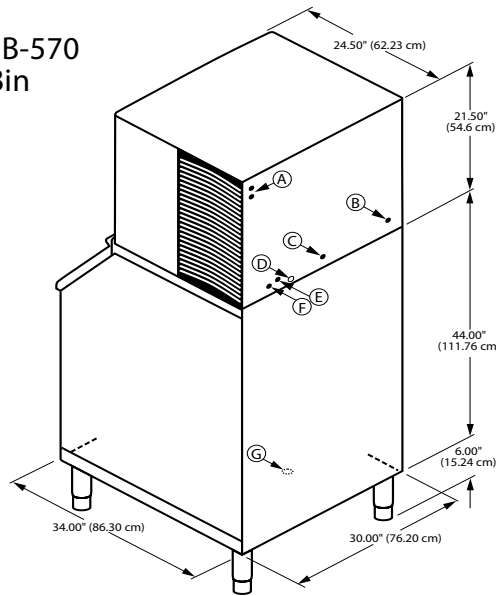

- Ⓐ Electrical Entrance (2) Options
- Ⓑ 3/8" (0.95 cm) F.P.T. Water Condenser Inlet (water-cooled units)
- Ⓒ 1/2" (1.27 cm) F.P.T. Water Condenser Outlet (water-cooled units)
- Ⓓ 1/2" (1.27 cm) Auxillary Base Drain Socket
- Ⓔ 3/8" (0.95 cm) F.P.T. Ice Making Water Inlet
- Ⓕ 1/2" (1.27 cm) F.P.T. Ice Making Water Drain
- Ⓖ 3/4" (1.91 cm) Bin Drain

Installation Note

Minimum installation clearance— Top/sides: 8" (20.32 cm), Back: 5" (12.70 cm).
 *Air-Cooled 50 Hz models are CE "T" rated for tropical applications up to 43°C.
 Minimum tropical rating installation clearance: Top 24" (60.96 cm) Sides/back: 12" (30.48 cm).

Space-Saving Designs



	S-500 B-400	S-500 B-570
Height	59.50" 151.13 cm	71.50" 181.61 cm
Width	30.00" 76.20 cm	30.00" 76.20 cm
Depth	34.00" 86.30 cm	34.00" 86.30 cm
Bin Storage	290 lbs. 131.54 kgs.	430 lbs. 195.04 kgs.

Height includes adjustable bin legs 6.00" to 8.00", (15.24 to 20.32 cm) set at 6.00" (15.24 cm).

For comparison purposes multiply ARI capacity by 1.3 (30%) to arrive at approximate "Application Rating Capacity."

*K-00214 bin adapter required.

Model	Ice Shape	Ice Production 24 Hours				Power kWh/100 lbs. @ 90°/70°F	CEE† Rating	ENERGY STAR®
		70°Air/50°F Water		90°Air/70°F Water				
		lbs.	kgs.	lbs.	kgs.			
SD-0502A	dice	530	240	420	420	5.5	Tier 3	★
SD-0503W	dice	550	249	470	470	4.3	Tier 3	
SY-0504A	half-dice	560	254	440	200	5.4	Tier 3	★
SY-0505W	half-dice	550	249	485	220	4.3	Tier 3	
Remote Air-Cooled with JC-0495 condenser								
SD-0592N	dice	510	231	425	204	5.8	Tier 3	★
SY-0594N	half-dice	480	218	450	193	6.1	Tier 3	★
Water usage/100 lbs./45.4 kgs. of Ice								
Potable Water: 18 gallons, 68 liters • Water-cooled Condenser: 138 gallons, 522 liters.								

†Consortium for Energy Efficiency (CEE) is a North American nonprofit organization that promotes energy-efficient products, technologies and services; also the principal entity for the development of ice maker efficiency standards.

Order ice storage bin separately. "A" or "W" following model number indicates "Air" or "Water" condensing unit.
 Ice storage bin and JC-0495A remote condenser must be ordered separately. Consult remote condenser specification sheet for details.

Ice Shape



Half Dice
 3/8" x 1 1/8" x 7/8"
 (.95 x 2.86 x 2.22 cm)



Dice
 7/8" x 7/8" x 7/8"
 (2.22 x 2.22 x 2.22 cm)

Air Flow Top View

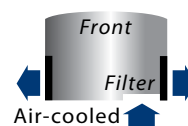

AuCS®SI Accessory



Automatic Cleaning System purchased factory installed in the machine or as an option for field retrofit.